



FLEXIVA™ FLX WITH POWERSMART® 3D

High Efficiency FM Liquid-Cooled Transmitter



The GatesAir Flexiva™ FLX with PowerSmart® 3D is a Liquid-Cooled FM solid-state transmitter family provides today's broadcaster with a single transmission platform capable of analog and digital. Built on the next generation of GatesAir's groundbreaking green transmission architecture, Flexiva transmitters offer today's FM analog or digital broadcaster compact, energy-efficient solutions to reliably deliver high performance and reduce Total Cost of Ownership.

Flexiva FLX utilizes the latest 50 volt LDMOS amplifier devices, compact high-efficiency power supplies, variable speed cooling and the Flexiva FAX exciter with RTAC™.

Featuring PowerSmart® 3D technology, the Flexiva FLX line offers unmatched efficiency that makes it ideal for all FM applications. FLX provides today's broadcaster with unparalleled power efficiency and outstanding signal performance.

This powerful blend of new technologies provides best-in-class performance with respect to transmitter power efficiency, physical size, performance and features. The modular design allows for simpler installation, infrequent maintenance requirements together with dramatically reduced total cost of ownership over the life of the transmitter.

Flexiva FLX Features

- Featuring 4th Generation HD Radio Crest Factor Reduction and Adaptive Pre-Correction technology for the highest HD Radio™ power available.
- Flexiva High Power Transmitter features identical power blocks for scalability. 10,000 Watts to 80,000 Watts
- Small and compact. 10kW power blocks in 16 rack units
- Variable speed coolant pumps and heat exchanger cooling fans maximize system efficiency
- Common dual power amplifiers and IPA modules for all power levels simplifies spares
- Single-phase or 3 phase power, Delta or Wye configurations. 190 to 464 VAC
- 1:1 Power supply to Power Amplifier module maximizes redundancy Hot-Pluggable, hot-swappable power amplifier and power supply modules minimizes down-time and simplifies maintenance.
- Simple, distributed hardware based control architecture uses analog circuits to control critical transmitter functions. Not reliant on a microprocessor for high reliability
- Hardware based life support backup controller provides added robustness, reliability
- Can use any standard FM exciter or can be tightly integrated with FAX low power exciter
- Fully broadband, 87.5 to 108MHz — requires no tuning or adjustments.
- Best-in-class power efficiency — lowest operating costs
- Extremely high power density; compact and lightweight space-saving design
- Latest state-of-the-art LDMOS-FET power amplifier technology, high efficiency (98%) auto ranging, hotpluggable power supplies
- Maintain power up to 1.5:1 VSWR with proportional VSWR fold-back above that for safe operation at reduced power into marginal loads (icy antenna etc.)
- Automatic restart after AC mains interruption; returns to previous operational mode
- Global control and monitoring via the World Wide Web remote graphic user interface (GUI) works with any PC, table or smart phone
- Full SNMP network control and monitoring support
- In-depth diagnostics and setup via an easy-to-use front panel control
- Dual-drive with automatic failover exciter switching

FLX 10K Available Options:

- Internal or External pump system

Product Details:

GatesAir PowerSmart 3D Technology Inside

GatesAir PowerSmart 3D Technology Inside. The Flexiva liquid cooled transmitter offers superior power density and by far the highest available system efficiency on the market.

This new amplifier design utilizes the latest 50 volt LDMOS device technology to deliver a dramatic increase in power density, lower operating costs and reduced cost of ownership over the life of the transmitter.

Compact Footprint

As the most compact liquid-cooled

FM transmitter, the Flexiva FLX is ideal for crowded, shared transmitter sites. The Flexiva FAX50 exciter drive further reduces rack space requirements. The Flexiva FLX transmitter reduces facility space requirements, simplifies installation, lowers shipping costs and allows for easier maintenance.

Highest Power Density

Flexiva FLX provides the highest power density with up to 20KW per rack, saving floor space.

Global Monitoring and Control

The Flexiva FLX transmitter can be controlled from anywhere in the world with an intuitive browser-based GUI or SNMP over TCP/IP via a telecom or network connection with password protection.

Improved Uptime and Reduced Service Costs

Hot-pluggable, redundant power

amplifier (PA) and universal power supply (PS) modules make on-air servicing easy and eliminate costly service interruptions. Lightweight universal PA pallets and universal PS modules facilitate overnight/same-day shipping for simple, cost-effective spares holding. With lightweight subassemblies, the Flexiva FLX eliminates any two-person lift requirements for routine maintenance and troubleshooting.

Smooth Upgradeability

The Flexiva FLX system features the new FAX G4 Engine technology, allowing for a seamless transition from analog FM to a digital standards such as HD Radio™ DRM+ or China Digital Radio

Flexiva™ FLX Block Diagrams

FLX 10K Dual Drive

FAX10k Transmitter/ Power block

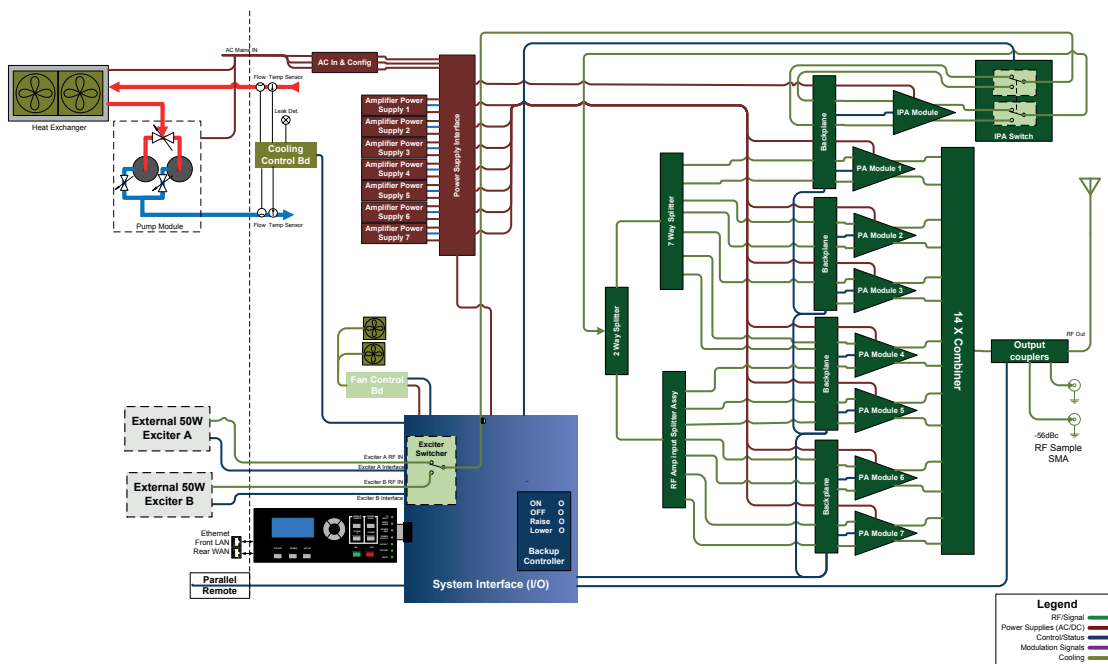

Flexiva™ FLX Liquid-Cooling Pump Modules

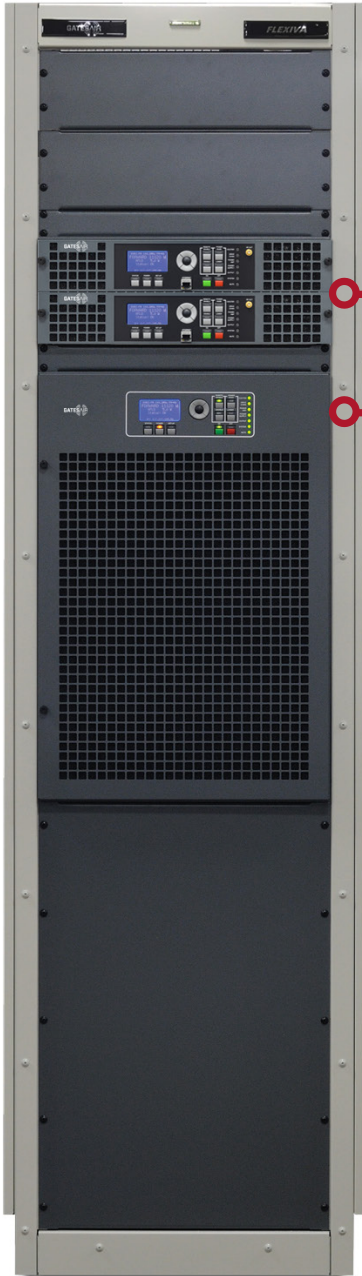

The FLX10K 10kW transmitter, can be supplied with a quiet, efficient internal dual pump module system

FAX Exciters

TX Power Block

External Dual Pumps, with auto/manual changeover

- Pump speed inverter controlled
- Optimized for High Efficiency
- Reliable, proven
- Small physical size
- Low maintenance, closed-loop pressurized system
- Quiet – Designed for indoor installation



PowerSmart® 



High Efficiency, Dual-Fan Outdoor Heat Exchanger

- Low noise, with high-efficiency fan blades
- Speed controlled for maximum efficiency
- Vertical or horizontal airflow
- Two sizes available 20kW & 50kW heat dissipation



Flexiva™ FLX

Specifications

Specifications and designs are subject to change without notice

General					
Transmitter Type	Solid State VHF Power Amplifier for FM, HD Radio, DRM+, and China Digital Radio				
Cooling System	Closed-loop, pressurized liquid coolant, Coolant: 50/50 Ethylene Glycol or Propylene Glycol and distilled water				
Exciter	External FM Exciter. Support for dual exciters with automatic changeover				
Frequency Range	87.5 to 108.0 Mhz, 10 kHz steps				
Operating Modes	"Quad-Mode" on-the-fly switching between FM HD only, FM+HD or DRM+				
Frequency Stability	±150 Hz				
Power Stability	≤ ±0.25 dB				
Asynchronous AM SNR	>60 dB				
Synchronous AM SNR	>50 dB				
RF Harmonic and Spurious Suppression	Meets or exceeds FCC, IC, CE, CCIR IRTU and IEC215 requirements				
VSWR	Protected against open or short circuit, all phase angles. Capable of operation into infinite VSWR with proportional foldback above user adjustable threshold of up to 1.5:1				
Compliance	RoHs 2011/65/EU, FCC, CE, IC, Directive 2014/53/EU compliant				
Output Power - Max Watts		FLX10K	FLX20K	FLX30K	FLX40K
Analog Only	Max Power	11,000	22,000	33,000	44,000
	Typically Efficiency	72%	72%	72%	72%
Analog @ -20dBc HD	Max Power	10,396	20,792	31,188	41,584
	Typically Efficiency	56%	56%	56%	56%
Analog @ -14dBc HD	Max Power	9,616	19,232	28,848	38,464
	Typically Efficiency	56%	56%	56%	56%
Analog @ -10dBc HD	Max Power	7,455	14,909	22,364	29,818
	Typically Efficiency	52%	52%	52%	52%
HD-Only -20 dBc	Max Power	4,000	8,000	12,000	16,000
	Typically Efficiency	42%	42%	42%	42%
HD-Only -14 dBc	Max Power	3,700	7,400	11,100	14,800
	Typically Efficiency	42%	42%	42%	42%
HD-Only -10 dBc	Max Power	3,100	6,200	9,300	12,400
	Typically Efficiency	42%	42%	42%	42%
Electrical					
AC Input Voltage Single Phase & 3-Phase (3-Wire) Delta:	190-264 47-63Hz				
3-Phase (4-Wire) Wye:	330-460 47-63Hz				
Power Factor	0.99% Typical				
Mechanical		FLX10K*	FLX20K	FLX30K	FLX40K
Width	23.5 in. (59.7 cm) 23.5 in. (59.7 cm) 47 in. (120 cm) 47 in. (120 cm)				
Depth	45 in. (115.3 cm) 45 in. (115.3 cm) 45 in. (115.3 cm) 45 in. (115.3 cm)				
Height	37RU 71 in. (181 cm) 44RU 83 in. (211 cm) 44RU 83 in. (211 cm) 44RU 83 in. (211 cm)				
Weight (approx w/ modules installed)	588 lbs, 267 kg 1002 lbs, 455 kg 1,700 lbs, 771 kg 2,200 lbs, 998 kg				
Environmental					
Altitude	15,000 ft. (4,572 m) AMSL				
Ambient Temperature Range	0° to 45° C (32° to 113° F) at sea level (upper limit derated 2° C (3.6° F) per 300 m (984 ft) elevation AMSL				
Humidity	95%, non-condensing				
Cooling Method	Liquid-cooled, using 50/50 mix of ethylene or propylene glycol and water				

*NOTE: Dimensions for the FLX10K reflect transmitter installed in 37RU deluxe rack.

FLEXIVA-FLX-ENG-JH-JD-071224