



MAXIVA™ XTE

Software-Defined Exciter for All TV and DAB/DAB+ Radio Standards

The new GatesAir Maxiva™ XTE exciter provides broadcasters with a powerful, software-defined platform, enabling the ultimate in performance, stability and durability.



Maxiva™ XTE Product Features

Cost-Efficient, Advanced Pre-correction

The Maxiva XTE incorporates advanced pre-correction techniques that assure optimum signal performance, linearity and efficiency for all types of power amplifiers. The GatesAir RTACTM system operates continuously, adapting to varying environmental and other conditions that could otherwise impact on-air performance.

Upgradeable & Flexible Design

The software defined XTE provides broadcasters the latest technology and digital correction for today's transmitter amplifier technologies. For example, SMPTE 2022 standardized IP technology for transport stream input and precision timing per IEEE 1588 lower overall infrastructure costs.

- Advanced Real-Time Adaptive Correction (RTAC)
- Optimized correction for all amplifier types
- Frequency Agile – Band I, III, IV and V
- Supports all widely used TV standards and DAB/DAB+ radio
- Upgradeable to emerging digital standards
- Available Internal GNSS (GPS/GLONASS) receiver for precision frequency control and/or timing required for SFN
- Available Internal UPS
- Compact 1RU design □ Dual redundant TSolP inputs with seamless auto-switching
- Dual redundant transport stream inputs with seamless auto-switching for ASI/ T2MI
- Integrated ISDB-Tb Remux
- Seamless integration with GatesAir transmitters
- Intuitive Web GUI interface with HTML
- Advanced monitoring and diagnostics support

Featuring unparalleled signal processing power, a smaller footprint and advanced Transport Stream over IP (TSolP) input capabilities, Maxiva XTE builds upon a strong legacy of groundbreaking technological advances, pioneered by several decades of GatesAir innovations. Dramatically increased processing power together with new, advanced Real-Time Adaptive Correction techniques, provides optimum signal performance over a wide variety of modulations and RF amplifier topologies. The Maxiva XTE supports a full range of digital broadcast standards, including ATSC, DVB-T/H, DVB-T2, ISDB-T, DTMB, and DAB/DAB+/DMB. It is upgradeable to future new modulations, including ATSC 3.0, as they become available.

Maxiva XTE Front and Rear

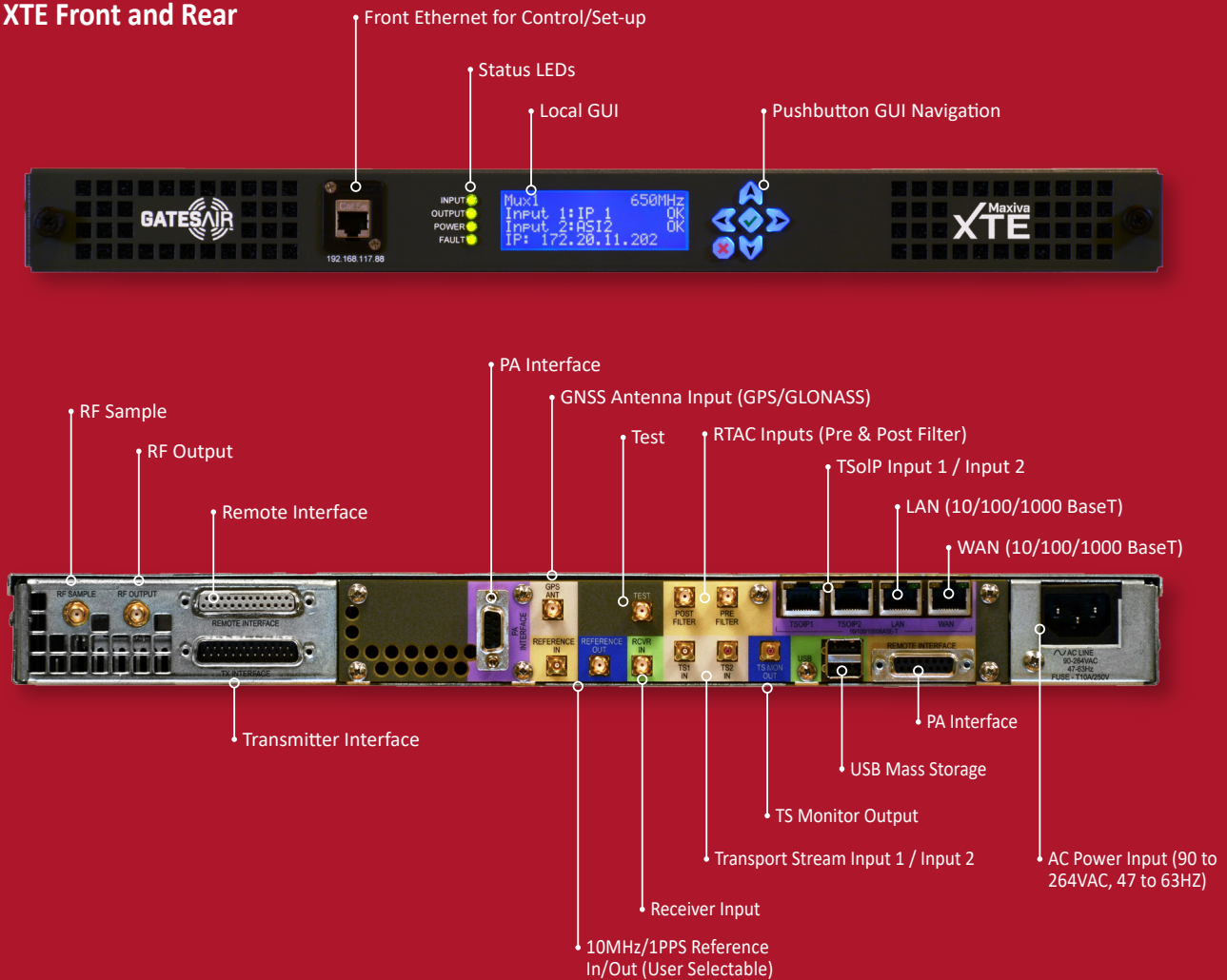

Maxiva XTE Front and Rear

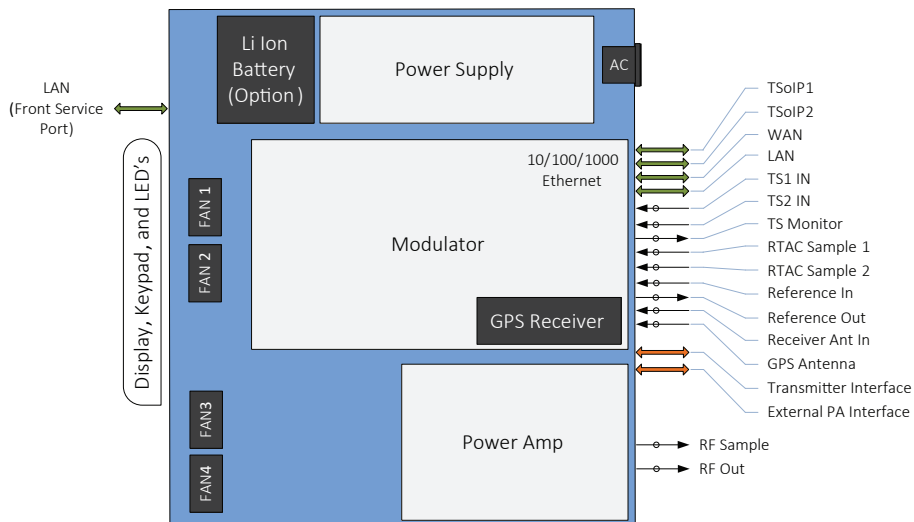

Maxiva XTE

Specifications

Specifications and designs are subject to change without notice

General	
Main RF Output Connector	1 Rear SMA, 50 ohms, Max. +20dBm (100mW)
Aux. RF Output Connector	1 Rear SMA, 50 ohms, Max. +20dBm (100mW)
RF Input Samples for Adaptive Correction	2 Rear SMA, 50 ohms dynamic range: -20 to +10 dBm
Frequency Range	VHF and UHF, Bands I/III/IV/V
Transport Stream Inputs	2 Rear HD-BNC, 75 ohms, configurable as DVBASI/T2-MI/SMPTE 310M/ETI
Transport Steam over IP Inputs	2 Rear RJ-45 10/100/1000 BaseT
10 MHz Reference Input	1 Rear HD-BNC 0 to +18dBm
1 PPS Reference Input	1 Rear HD-BNC TTL level
10 MHz Reference Output	1 Rear HD-BNC
1 PPS Reference Output	1 Rear HD-BNC
Ethernet	1 Front RJ-45, DHCP enabled, customer access
LAN	1 Rear RJ-45 10/100/1000 BaseT
WAN	1 Rear RJ-45 10/100/1000 BaseT
USB Mass Storage	2 Rear (USB 2.0 High Speed)
GNSS Antenna Input (GPS/GLONASS)	1 Rear SMA 50 Ohms
AC Power Input	90 to 264 VAC, 47 to 63 Hz, autoranging
Environmental	Temperature range: 0° to 50°C (32° to 122°F) up to 4,500 m (14,764 ft) AMSL. Derate 2° C (3.6°F) per 984 t (300 m) of elevation Humidity: Up to 95% relative humidity, noncondensing
Physical	19 in. EIA rack standard, 1RU high, 19 in. depth
ATSC Specifications	
Standards	ATSC A/53, A/153, A/110:2011
Maximum Power Output	+20dBm (100mW) Average
Regulation of Output Power	<0.25dB
Pilot Frequency Stability	Without precision frequency control/GPS: ±150 Hz/month (2.3 x 10 ⁻⁷ ppm)
Frequency Setting / Offsets ¹	Any frequency within band, with 1Hz setting increments
Frequency Response variation	0.2dB, typical
Group Delay	2nS, typical
Phase Noise	<104dBc/Hz@ 20kHz offset (ATSC A/64)
Spurious Output ²	In Band: -68dB (-45dB as measured in 30kHz RBW) Adjacent channels: -68dB (-45dB as measured in 30kHz RBW) All others: -40dB
Signal to Noise Ratio (SNR)	35dB, typical
Type/class of Emissions	C7W (8VSB, ATSC1, ATSC2)

Note:

¹ High-stability external 10MHz/1PPS reference, or optional built-in GNSS receiver required for SFN

² Signals referenced to center channel, at rated output power, measured with 30kHz RBW

Maxiva XTE

Specifications

Specifications and designs are subject to change without notice

ATSC 3.0, DVB-T, DVB-T2, ISDB-Tb, DAB/DAB+/DMBT Specifications	
Maximum Power Output	+20dBm (100mW) Average
Regulation of Output Power	<0.25dB
Frequency Stability	Without precision frequency control/GPS: ± 150 Hz/month (2.3×10^{-7} ppm)
Frequency Setting / Offsets ¹	Any frequency within band, with 1Hz setting increments
Frequency Response Variation	0.2dB, typical
Group Delay	2nS, typical
Phase Noise	10Hz: ≤ -55 dBc/Hz 100Hz: ≤ -85 dBc/Hz 1kHz: ≤ -90 dBc/Hz 10kHz: ≤ -95 dBc/Hz 100kHz: ≤ -112 dBc/Hz 1MHz: ≤ -130 dBc/Hz
Spurious Output ²	In Band: -68dB (-45dB as measured in 30kHz RBW) Adjacent channels: -68dB (-45dB as measured in 30kHz RBW) All others: -40dB
Modulation Error Ratio (MER)	38dB, typical
Central Carrier Suppression	>75dB relative to average power
Out of Band Shoulders	>50dB, uncorrected, at rated average power
Type/class of Emissions	X7F / X7FXF (COFDM, ATSC3, DVB-T/T2, ISDB-T, DAB & DTMB)

Note:

¹ High-stability external 10MHz/1PPS reference, or optional built-in GNSS receiver required for SFN

² Signals referenced to center channel, at rated output power, measured with 30kHz RBW