

Tubes to Solid State Liquid or Air

GATESAIR®



Steven Rossiter
Sr. TV & RF Systems
Applications Engineer
GatesAir
2023

Tubes to Solid-State Transmitters

- Considerations Tube or Solid State
- Solid State balanced amplifier and Solid-State High efficiency amplifier
- Packaging & Doherty Amplifiers



LET'S TALK TUBES - IOT, MSDC AND ESCIOT



- Inductive output Tube – an IOT is a high-power linear beam vacuum tube. Like the old cathode ray tube used for your TV

- The transmitter IOT system efficiency for a UHF TV system was at best 28%

	Klystron	Klystron sync. pulsed	Klystron MSDC	Transistor	Tetrode	IOT	Diacode
Invention	1939	1975	1982	1948	1936	1938	1990
Adoption	1960	1980	1985	1970	1975	1990	1994
Gain (dB)	40	40	40	7	13	20	13
Electrical efficiency (grey and sync.) (%)	9	14	28	16	24	32	29
IPD (dB)	-40	-40	-40	-40	-50	-50	-50
Common amplification	no	no	no	yes	yes	yes	yes
Maximum power per device (kW)	70	70	70	0.1	50	110	100
Typical average life (hours)	50 000	25 000	50 000	>50 000	15 000	30 000	15 000

The newest versions of IOTs achieve even higher efficiencies, Multistage Depressed Collector (MSDC) and ESCIOT (Energy Saving Collector IOT) can achieve efficiencies of 60%-70%, with complete transmitter system efficiencies of 45%-50%.



SOLID-STATE BALANCED AMPLIFIER

- The first solid state broadcast amplifiers for TV & FM were mostly lower power air-cooled systems using, Class B, AB and Class C amplifiers depending on the frequency and uses.
- The best efficiency of a typical solid state UHF amplifier using class AB was only in the range of <12% to <19%
- If you look at each class of amplifier for solid-state applications, the component efficiencies were from 15% to 70%. Then you add the system efficiencies that number is reduced to 8% to 60% depending on frequency, use and class of amplifier.
- These older Solid-State broadcast transmitters were much lower power and had lower efficiencies. So, Ask yourself

With Tube efficiencies higher than Solid-State

What Changed?

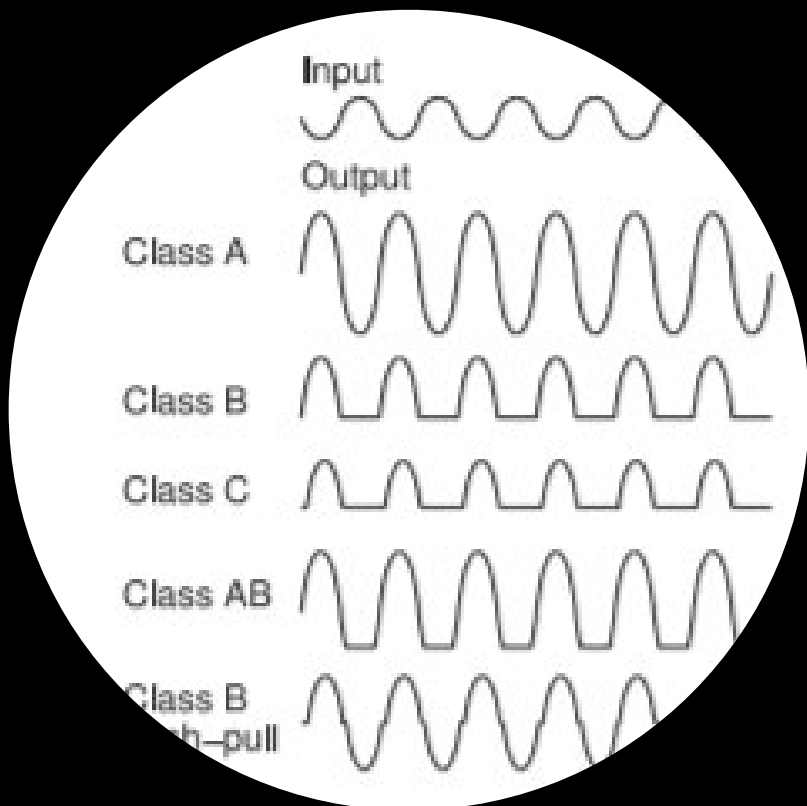



SEMICONDUCTOR DESIGN & PACKAGING

New high efficiency semiconductor packaging and Doherty amplifier design, the efficiencies were increased to 50% to 85% for the amplifier devices, and transmitter system efficiencies changed to >35% to >70% depending on use and frequency.

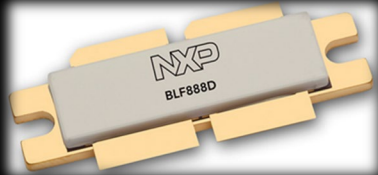

Advancements in how devices are packaged



75kW Average Power in $\frac{1}{2}$ the space as a Tube System



The innovation lead the way for higher power, higher efficiency amplifiers for broadcast transmitter design using Solid-State LDMOS (laterally-diffused metal-oxide semiconductor) transistors. The new devices are more robust device using rugged LDMOS design. Higher gain & higher power



The packaging advancements in LDMOS technology helped reduced space (footprint) utilized by the transmitter for the same amount or more power. Tubes took a lot of space in the transmitter room.



Tubes were a single point of failure, you lost a tube you were off the air, unless you were lucky to have more than one. Many Solid-State devices used in parallel can achieve the same high-power levels in a modular design with an extreme amount of redundancy and life span.



Tube transmitters are very complex and required a lot of maintenance to keep them operating. Solid-State circuits are less complex and required less maintenance.



Tubes required very high power and high voltages, which are dangerous to repair. Solid state devices only required 35V DC– 50V DC and with modular design & multiple power supplies easier to repair.



- William H. Doherty an American electrical engineer, invented the first Doherty amplifier in 1936 in the Bell Telephone Laboratory.
- The Doherty amplifiers are not new, but with new semiconductor design techniques and advances in technology we can now leverage the Doherty amplifier design in the UHF broadcast transmitters of today.

DOHERTY AMPLIFIER

POWER AMPLIFIER DETAIL – WHAT IS DOHERTY AMP.

The Doherty High Efficiency amplifier provide improved efficiency compared to balanced amplifiers.

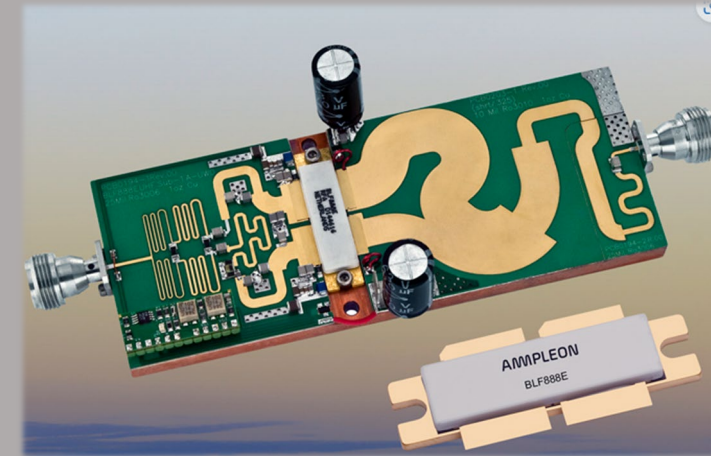
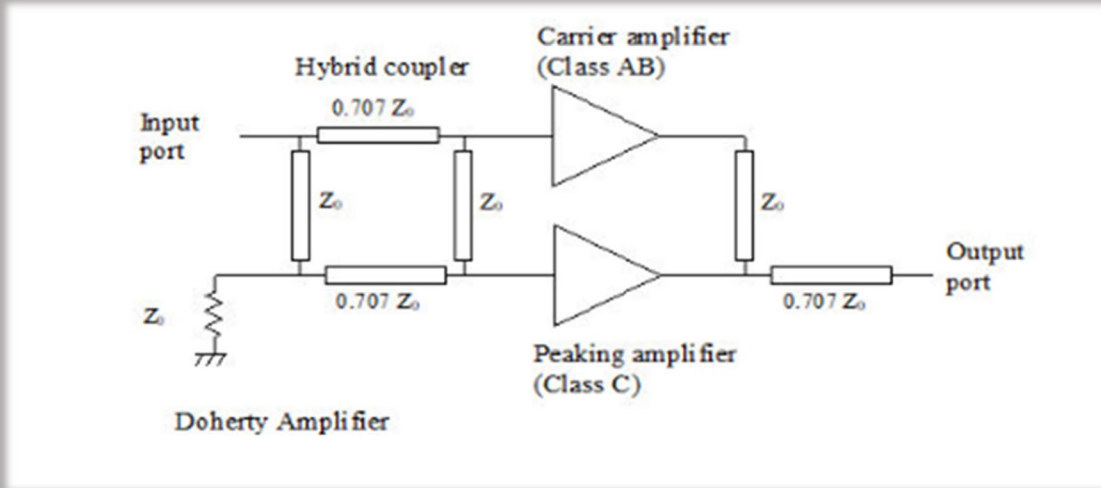

The Doherty amplifier power-combines two amplifier types, one is called the “Carrier or Average” amplifier while the second is called the “Peaking” amplifier. In many Doherty amplifiers the two amplifiers are biased differently, the carrier amp is at a normal Class AB, while the peaking amplifier is at Class C to control its conduction at only higher levels of the envelope. The beauty of the Doherty amplifier is it improves power-added efficiency, compared to a balanced amplifier, at backed off power levels.

Liquid Cooled & Air-Cooled FM & TV Transmitters

- Considerations Air or Liquid Cooling
- Various components and architecture
- AC to RF Operating benefits of Solid-State Transmitters



Air Cooling

- Works with existing transmitter rooms, that currently have air cooled transmitter systems.
- Reduces reliance on outside space or additional Ice protection for outdoor equipment like pumps or heat exchangers for liquid cooled system.
- Simplified operations – No pumps, Heat exchangers or liquid leaks.
- Maintenance – no cleaning of outdoor heat exchangers required for liquid cooled systems - does require cleaning or changing of air filters. No pump replacement or liquid leaks.
- Typically, in cold environments additional site heating is not required - using the waste heat from the transmitter.
- Modular design



Components & Architecture

Transmitter

- Power Supplies
- Hot swappable

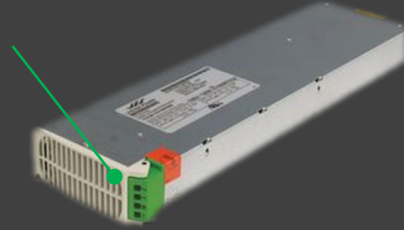

AIR Cooled Module

- Power Amp Module
- Hot Swappable

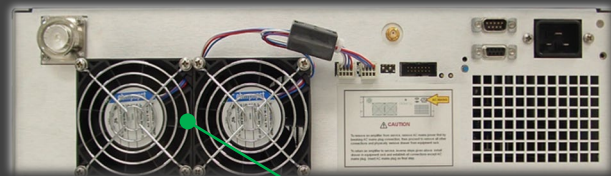

AIR Cooled module

- Redundant Fans



AIR COOLED

- AC Distribution
- Exciter switching unit
- Dual exciter (optional)
- Field Serviceable

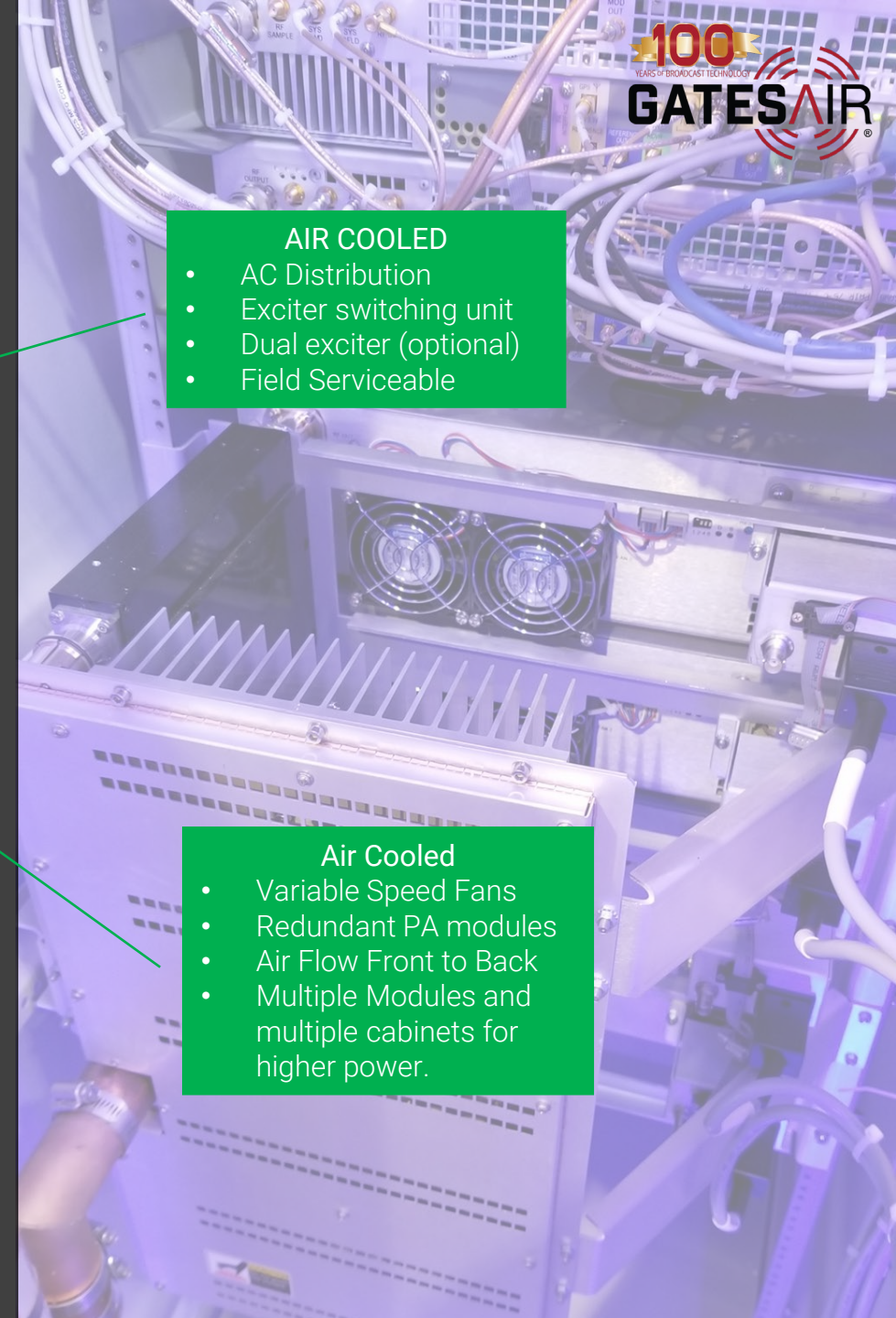

Air Cooled

- Variable Speed Fans
- Redundant PA modules
- Air Flow Front to Back
- Multiple Modules and multiple cabinets for higher power.



Air Cooling Methods

Three air cooling methods for broadcast transmitters can be considered:
1. Air-cooled using outside air only (no air-conditioning), Great for cooler dry climates.

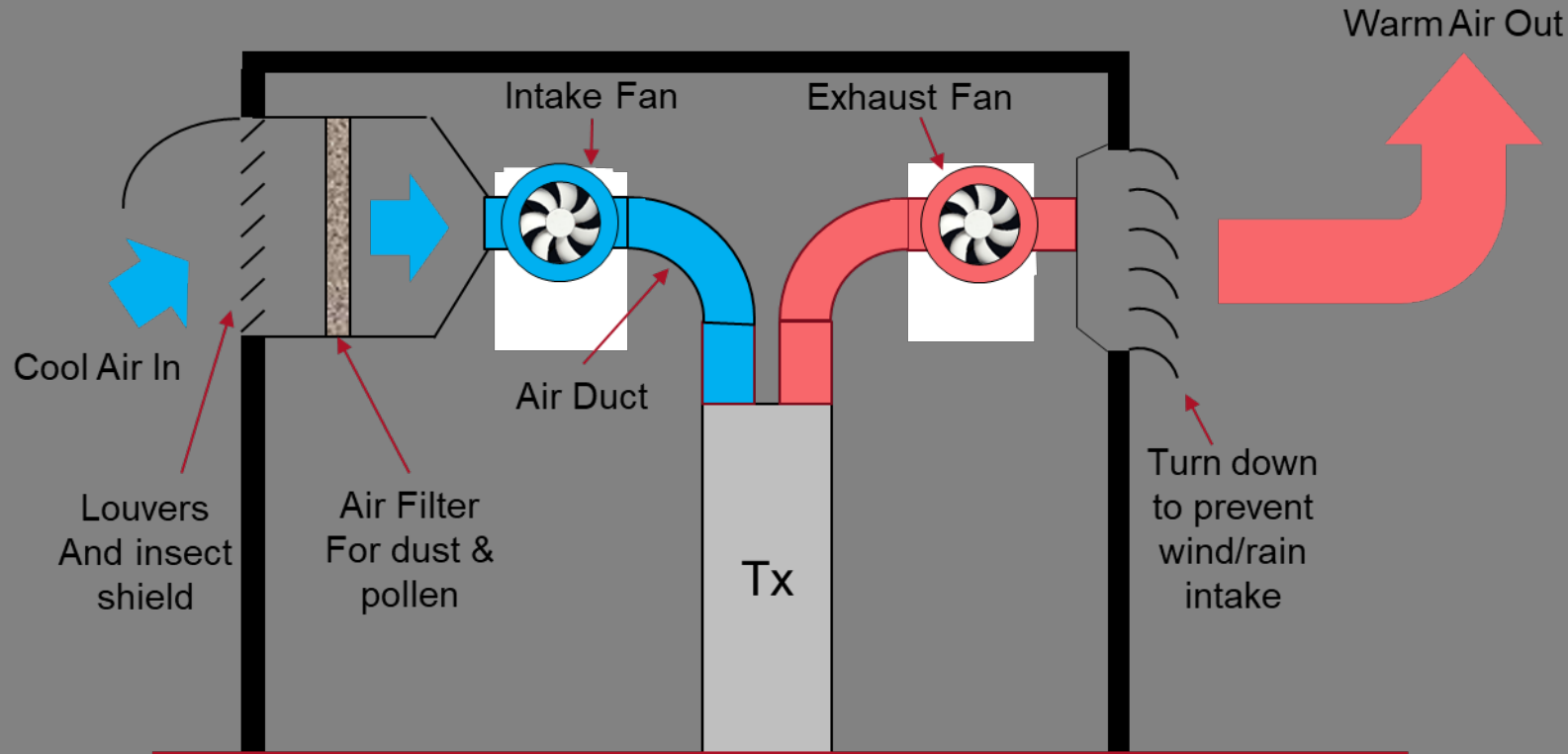

Energy Cost = Low
Installation cost= High
Maintenance cost = High

Site Visits = Frequent
Humidity Control = None
Dust & Dirt = Filter dependent

Reliability = Low



Air Cooling Methods

2. Air-cooled using inside air only and Air-Conditioning (sealed room)
Recommended for hot and or humid climates.

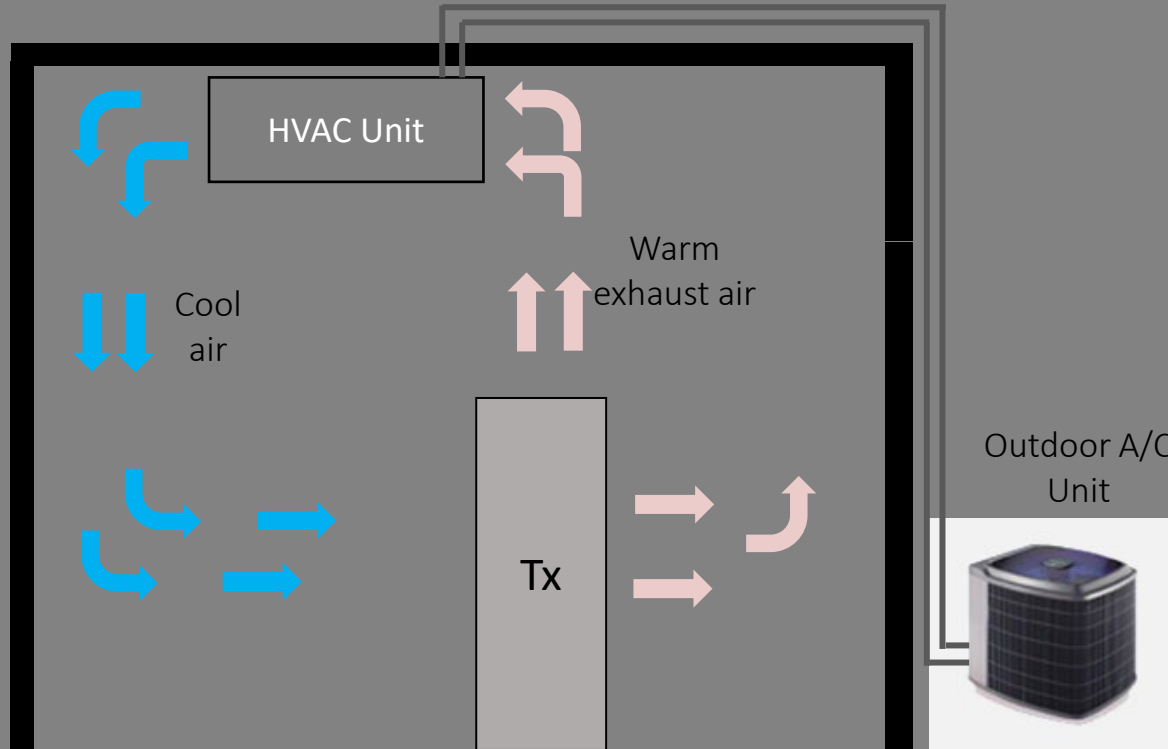

Energy Cost = High (HVAC)

Installation cost= Low

Maintenance cost = Medium

Site Visits = Infrequent

Humidity Control = Excellent

Dust & Dirt = Excellent

Reliability = Good

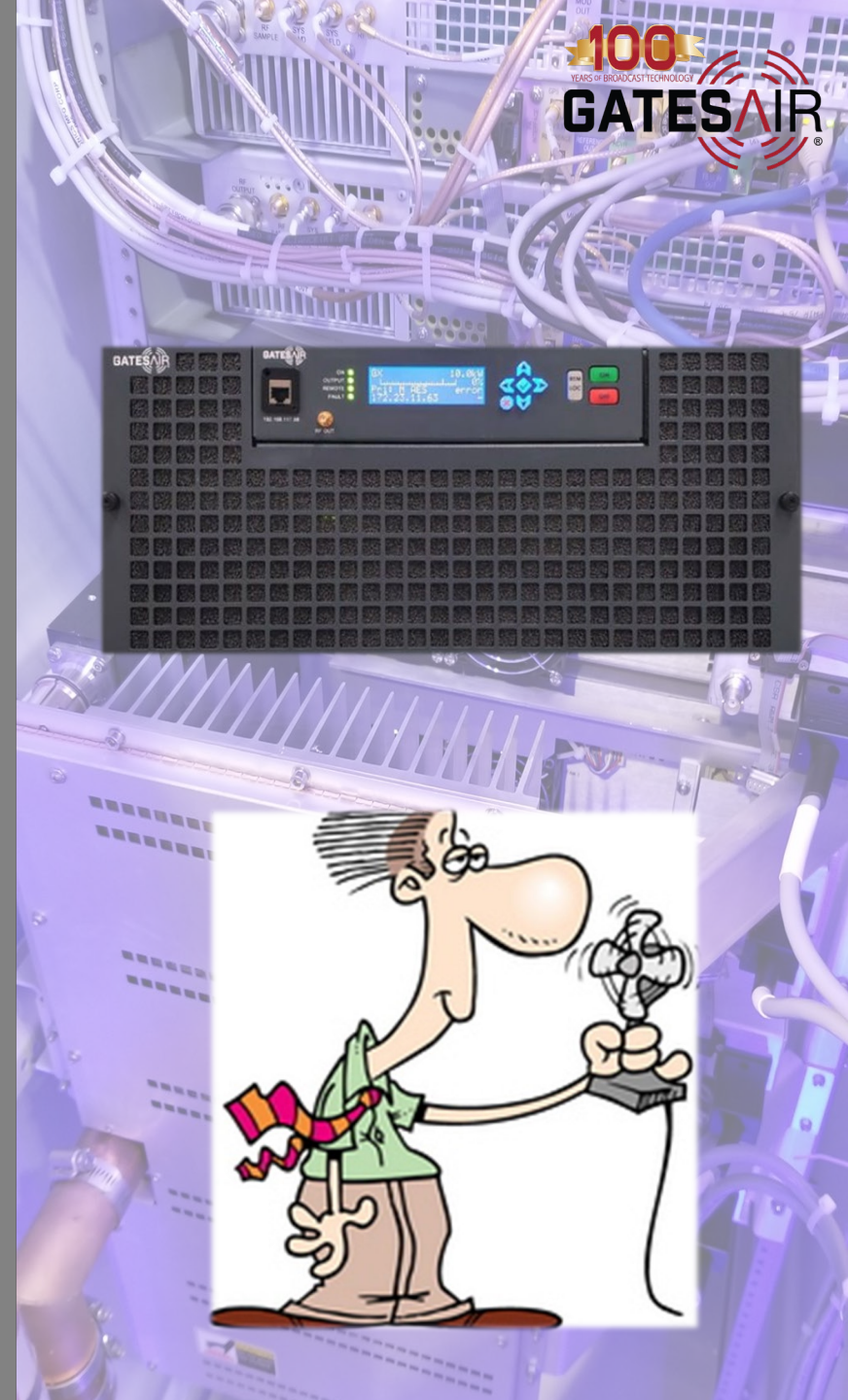

Air Cooling Methods

3. Air-cooling using outside air and air conditioning.

Not Recommended, requires high cooling capacity due to high volume of warm intake air.

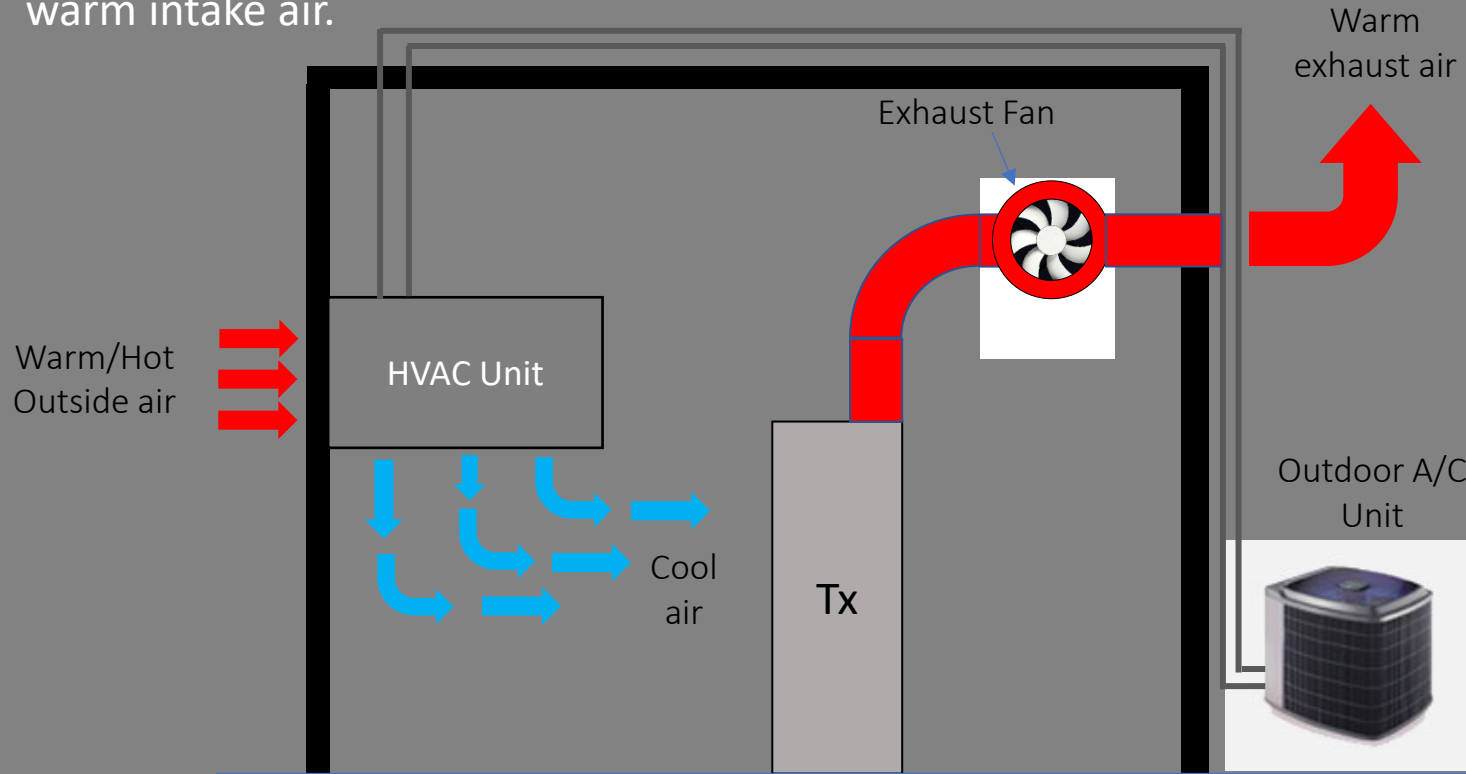

Energy Cost = Highest (HVAC)

Installation cost= High

Maintenance cost = Medium

Site Visits = Frequent

Humidity Control =Medium

Dust & Dirt = Filter dependent

Reliability = Not so good





Liquid Cooling

- Reduces cooling requirements – TX site building heat Loads are minimized by use of heat exchanger outside.
- Reduces reliance on outside services – HVAC regular maintenance
- Simplified operations – less filters to clean, noise reduction, less maintenance
- Total Cost of Ownership – Total cost to own and operate the transmitter system over time costs less, reduced HVAC cooling requirements. Heated cooling liquid can be used to heat the building in cold weather environments.
- Modular design
- The old saying you should not mix water and electricity, well that's not so true.

Components & Architecture

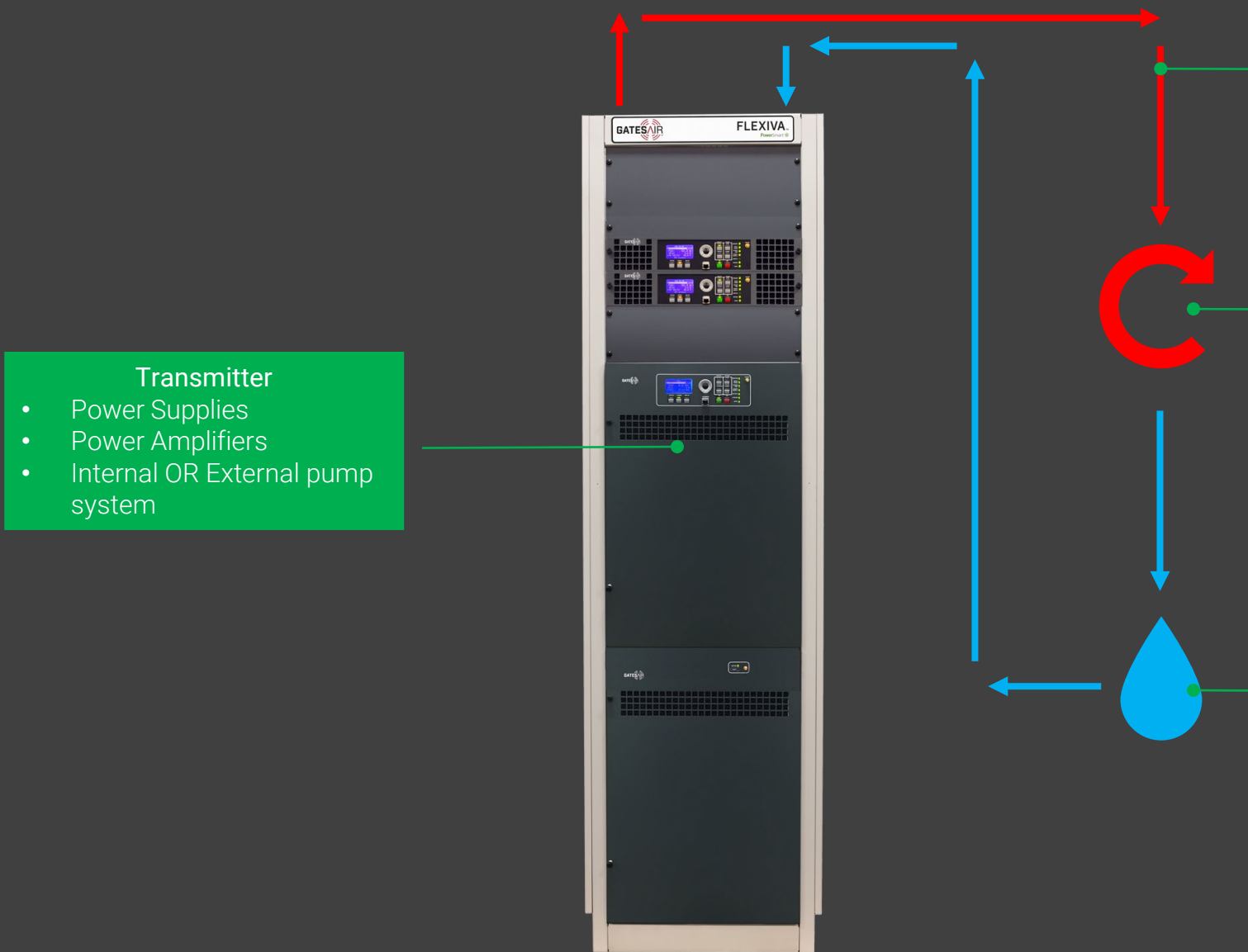

Transmitter

- Power Supplies
- Power Amplifiers
- Internal OR External pump system

Plumbing Flexability

- Hose system
- Soldered Copper pipe
- New Press-fit Copper pipe

Heat Exchanger

- Variable Speed Fans
- Redundant Fans
- Flexible Mounting
- Field Serviceable

Pump System

- Variable Speed Pumps
- Redundant Pumps
- Pump Control System
- Field Serviceable
- Off the shelf coolant

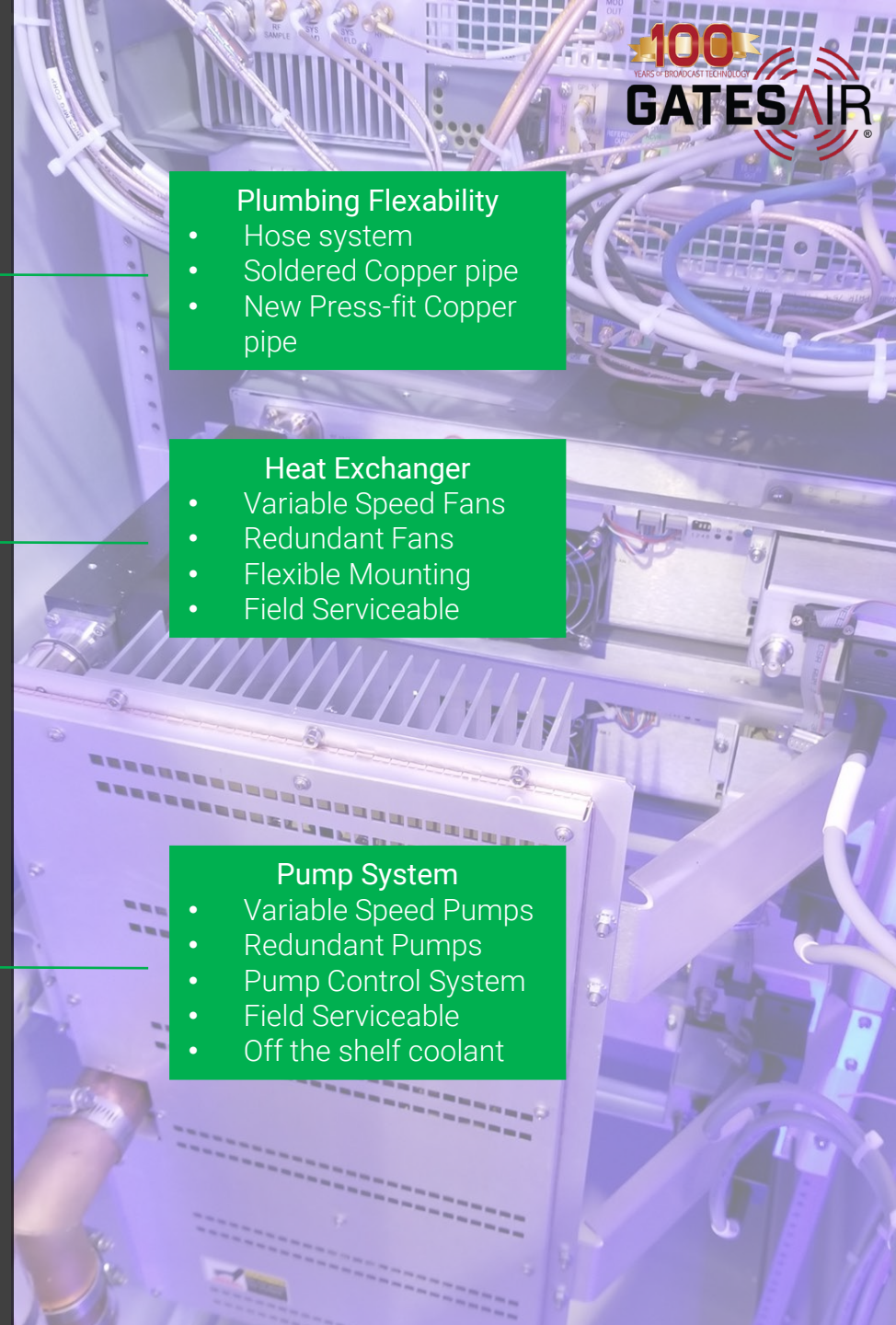

FM & TV Transmitters

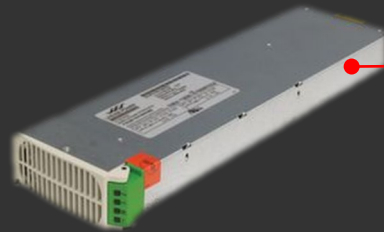

- ### Power Supplies
- 96%+ Conversion Efficiency
 - Excellent MTBF (900k Hours)
 - Easily procured – nonproprietary part
 - More efficient than liquid cooled power supply

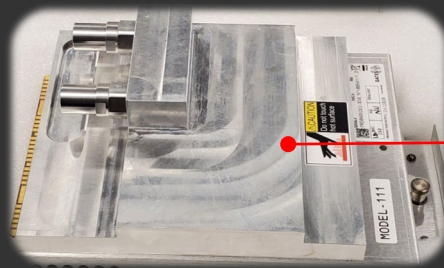

- ### Power Amplifiers
- Dual 50v LDMOS FET's for each PA Pallet
 - TV Multipule pallets per module
 - Completely Hot swappable/Hot pluggable PAs for both FM and TV products.
 - Self sealing liquid connectors
 - Chiller plate used to cool PA Modules

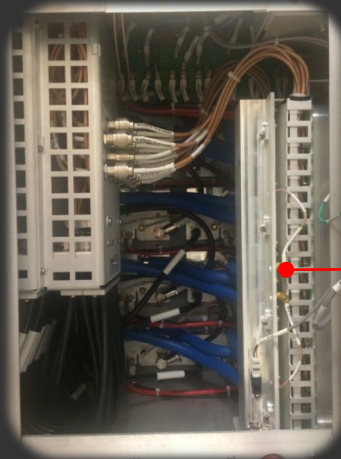

- ### Distribution System
- Chiller plate for Combiner reject loads
 - Variable speed flushing fans
 - Manifold to distribute liquid to PA's and PA blocks

Heat Exchanger



- ### Fans
- 100% Redundant & Variable speed
 - Easy disconnect for on-air maintenance
 - Protection and shielding of vulnerable components
 - Quiet designed fan blades to reduce outside noise in populated areas.



- ### Mounting
- Can be mounted horizontal or vertical
 - Provide clearance for intake & exhaust
 - Units can be stacked to minimize space
 - Wall mounted when ground space is not available

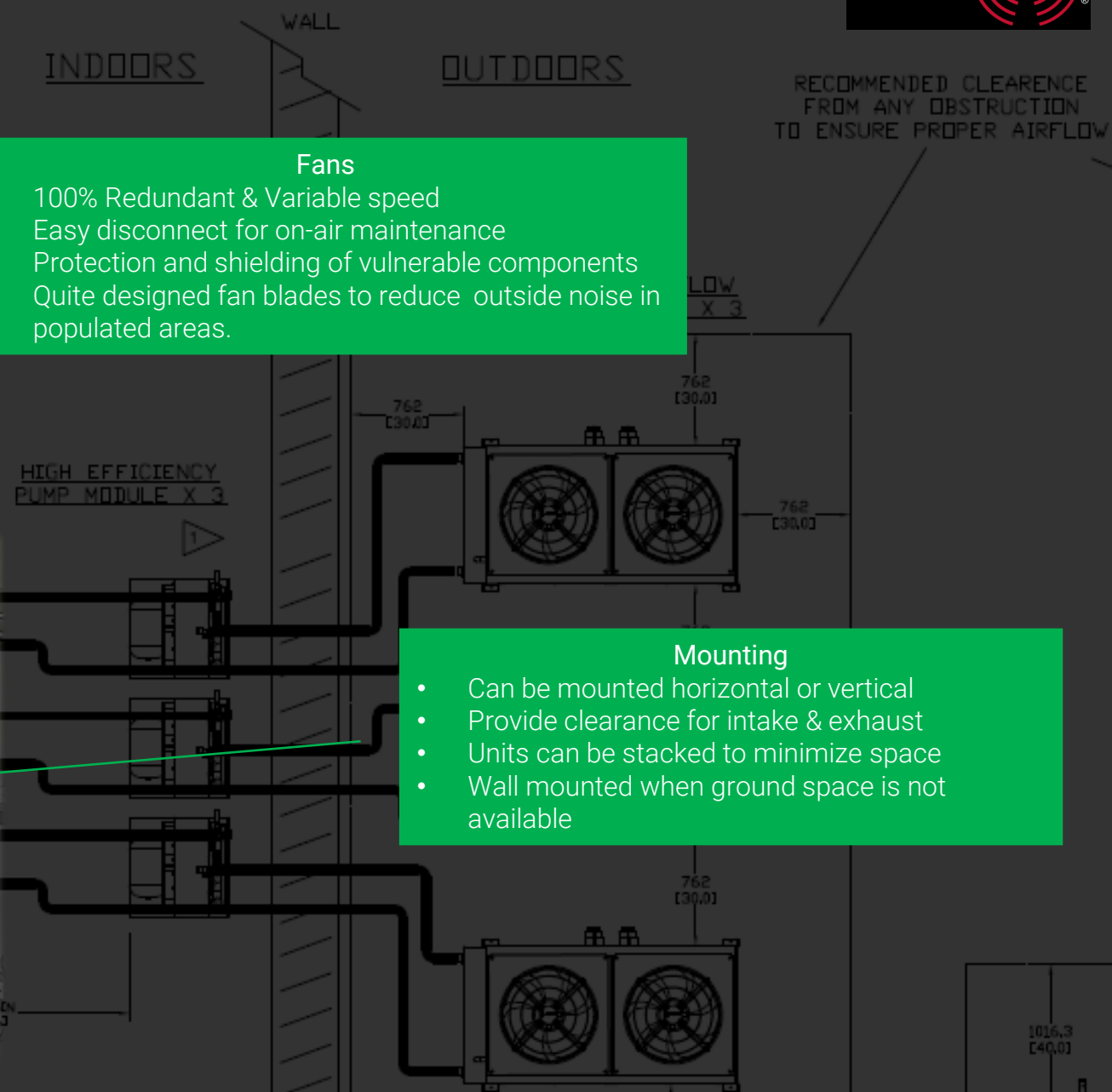

Pump System



Coolant Flow

- Flow varies by PA quantity
- Min. flow 8 GPM, Max. flow 64 GPM
- Integrated flow meter

Variable Speed

- Adjust pump speeds based on liquid temperature
- Adjust Heat exchanger fan speeds based on liquid temperature.

Distribution

- Bypass manifold assembly
- Sight glass to monitor fluid level and flow
- System air purge

Internal to the Rack Pumps
Dual Pumps for Redundancy

Expansion Tank

- Provides pressure relief to system

External to the Rack Pump Module
Dual Pumps for Redundancy

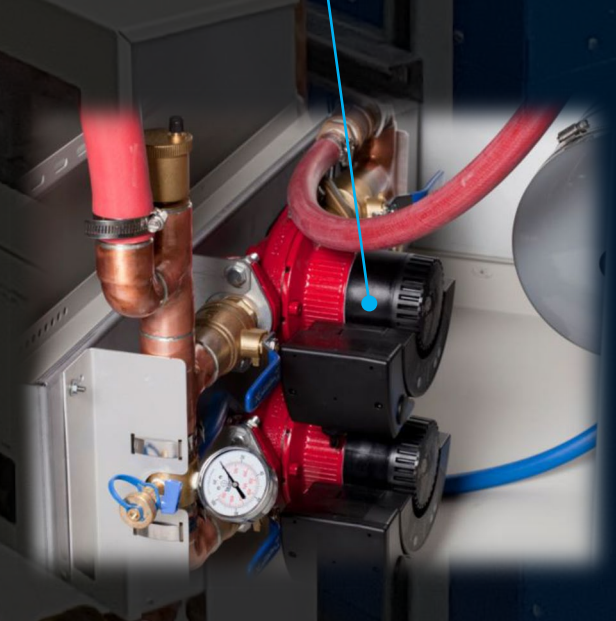
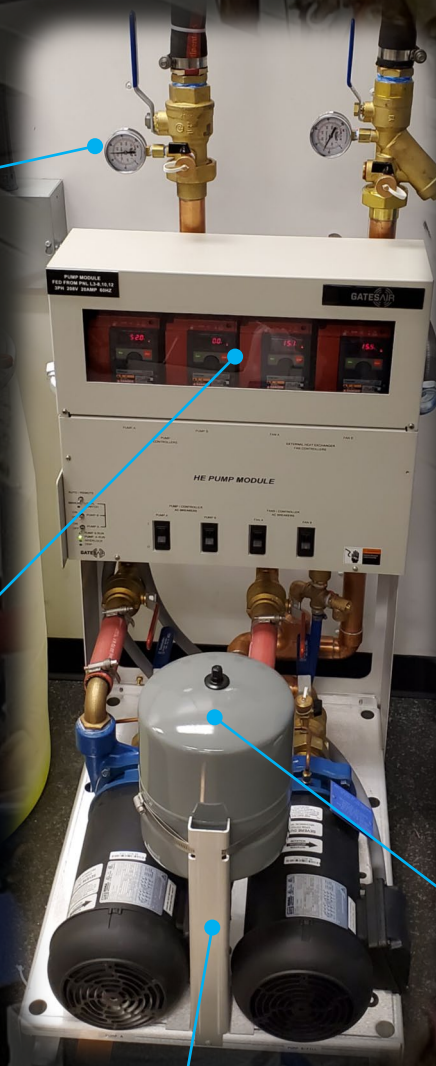
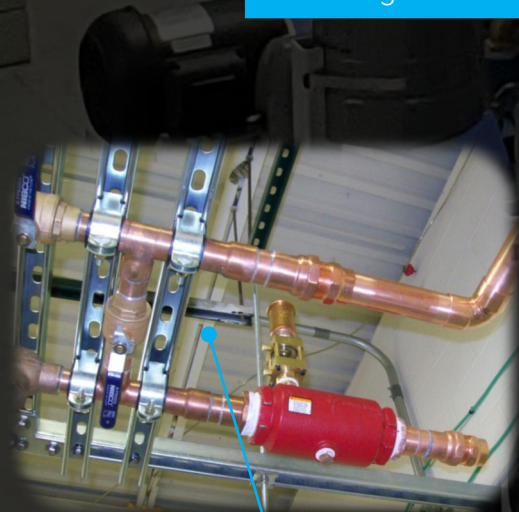

Transmitter Management

Key Benefits of IP = Control & Monitor

- Meter
- Status
- Command
- Requires MIB tables from Manufacturers

GUI Features

- PA and PA health status
- Cooling system status & diagnostics
- Restart profiles
- Different user credentials
- Remote enabled upgrades

gates (Engineer) Logout
Flexiva
FAX FM TX FAX 20K FM
Off Forward 0 W 10:53
Reflected 0 W 08/19/2015
Home Event Log
DRIVE CHAIN
Exciter A IPA Power Amps Output
Exciter B
SYSTEM
Control Cooling Power Supplies
Mode: FM Frequency: 0.00 MHz
Primary Faults
AC Mains External Interlock VSWR
Exciter Trip IPA Trip Foldback
Power Supplies System

REMOTE ENABLE POWER RAISE
DISABLE LOWER
ON OFF

- Exciter ●
- Drive Chain ●
- Power Amp ●
- Power Supply ●
- Output ●
- System ●
- Mute ●
- Exc A On Air ●
- Exc B On Air ●

GATESAIR
QCY HPLAB-10 ULXTE-10 ATSC3.0 Maxiva™
On Off Login
Menu Event Log
Forward 6.5 kW 98%
Reflected 0 W
539.00 MHz A18 08/23/2023 16:36
Home
Transmitter
Exciter A P/G Power Amps Output
Exciter B
Control Power Supplies Cooling
PB 1
Status
Cooling
Power Amplifiers
Exciter ● Output ●
Drive Chain ● System ●
Power Amp ● Mute ●
Power Supply ● Remote Enabled ●

GUI Interface

- FM Air & Liquid transmitters and TV Air & Liquid transmitters all have the same look and feel, helps with engineers and sites with FM and TV transmitters.

New Transmitter System Benefits



New Solid-State Transmitters - Lower Cost of Ownership

- Better RF to AC efficiency than the old IOT and old amplifiers, lower cost of ownership.
- Less space smaller footprint
- Possible rebates from AC service providers
- Smaller HVAC systems required for new air-cooled transmitters due to better efficiency and liquid cooled systems better efficiency and putting heat outside, reduces HVAC cost.
- Less maintenance for solid-state system. With limited engineering resources today new transmitters solid-state transmitters require less maintenance so less cost of Ownership.



Simplified TX Operations & Management

- Better Transmitter control and management with enhanced high speed IP interface and connections (both air and liquid).
- Enhanced monitoring & Control options – GUI interface, SNMP, Parallel remotes.
- Adaptive precorrection simplifying the operation and compliance.



Liquid cooled Improved TV Capabilities

- Better RF to AC efficiency than air cooled
- Liquid cooled transmitter available in VHF - Low Band & High Band, UHF – Band IV / V
- ATSC 3.0 Compatible as well as other modulations including analog.
- Transmitter Power levels from 1kW to 200kW
- Lower cost of ownership using high efficiency amplifiers.
- Low band , High band and UHF transmitters available

Liquid cooled Improved FM HD Capabilities

- Better RF to AC efficiency than air cooled
- TPO Sample: 28.5kW at -14dB HD
 - (Air Cooled 40kW vs. Liquid Cooled 30kW)
- TPO Sample: 18.5kW at -14dB HD
 - (Air Cooled 30kW vs. Liquid Cooled 20kW)
- When comparing for HD requirements
 - FLX provides savings in 3-5 yrs

Air Cooled FM or TV

- Fits with existing infrastructure where air cooled was used in the past.
- Waste heat used to heat the room in cold environments.
- Multiple cooling configurations possible depending on site and environment.
- TV Power Levels from 100mW to 32kW
- Low band, High band and UHF transmitters available
- FM Power Levels from 50W to 40kW



What would you choose?

Thank You

Steven Rossiter
Sr. TV & RF Systems
Applications Engineer
GatesAir
2023